



Baby Monitor

Secure 100



User Guide

TABLE OF CONTENTS

WARNINGS AND SAFETY INFORMATION	1
GETTING STARTED	3
YOUR BABY MONITOR	5
BASIC OPERATION	8
TROUBLESHOOTING	11
PRODUCT SPECIFICATIONS	12
GUARANTEE	13

Need Help?

If you need assistance setting up or using your Oricom product now or in the future, call Oricom Support.

Australia	1300 889 785 www.oricom.com.au Mon-Fri 8am – 6pm AEST
New Zealand	0800 67 42 66 www.oricom.co.nz Mon-Fri 10am – 8pm NZST

IMPORTANT

Please read this user guide thoroughly before use.

Your ORICOM Baby Monitor is designed to be an aid and should not be used as a substitute for responsible and proper adult supervision of a child.

The Baby Monitor has been designed to provide some added reassurance in the form of sound transmission for those times when you are not in the same room as your baby provided you always stay within hearing range of the baby monitor during use. Your Baby Monitor is not a medical device, nor a device to prevent cases of Sudden Infant Death Syndrome (SID'S) or "cot death", and you should not rely on it for your baby's wellbeing. It is important that you regularly check on your baby personally.

Make sure the Baby unit, Parent unit and mains adaptor cables are kept out of reach of your baby and other young children within the house at all times, at least one metre away from the baby's cot.

Never place the baby unit inside your baby's cot, bed or playpen.

Never cover the Parent or baby units with clothes, towels or blankets or any other item.

Do not place the cord in a high "wear and tear" location. Never use a frayed or compromised cord.

Never use or place your Parent or Baby units in or near moisture or water (e.g. near bath or pool). Immersing in water can cause electric shock and even death.

Power requirements

In Australia this product requires an electrical supply of 220-240 volts, single phase/alternating current.



CAUTION

Use only the mains power adaptors supplied with this equipment. Incorrect adaptor polarity or voltage can seriously damage the unit and/or cause physical harm and even death. The adaptors may become warm during use, please take care when handling.

AC Adaptor (Baby unit)

Input: 100-240V_{AC} 50/60Hz

Output: 6V_{DC} 500mA

AC Adaptor (Parent unit)

Input: 100-240V_{AC} 50/60Hz

Output: 7V_{DC} 420mA

If you plan to use your Baby monitor whilst travelling overseas, make sure that the voltage shown on the mains power adaptor is the same as the local mains power before connecting to the power supply. Do not use any voltage converter with the monitor.

2

WARNINGS AND SAFETY INFORMATION

- Do not dispose of the battery in a fire, as they can explode.
- Do not open, unscrew or tamper with any part of this product. Should your product go faulty; contact Oricom Support 1300 889 785 or 02 4574 8888.
- Released electrolyte from the battery is corrosive and can cause damage to the eyes or skin. It can be toxic and fatal if swallowed.
- When your Baby Monitor is not in use, it is recommended that you disconnect it from the mains supply and remove the battery.
- Observe the proper polarity and direction of the battery when inserting. The black lip must be facing downward as illustrated below.
- The Ni-MH battery supplied with this product may be recycled once it is unable to recharge during normal operation. Always observe your local Council /State regulations regarding the disposal of your packaging materials, exhausted batteries, and old equipment.
- Always recycle where possible. Do not use your baby monitor in an explosive hazard area such as where there is gas leaking.
- As there is a slight chance that the product could be damaged by an electrical storm, it is recommended that users unplug from the mains supply during an electrical storm.

Cleaning and care

The surface of the case can be cleaned with a dry, soft, lint-free cloth. Never use cleaning agents, particularly aggressive solvents. Apart from occasional cleaning of the case, no other care is necessary.

Thank you for choosing this monitor from Oricom.

Your Secure 100 Baby Monitor offers the best Digital Technology.

INTERFERENCE FREE FREQUENCY



DECT (Digital Enhanced Cordless Telecommunications) is the most widely used worldwide digital cordless technology, offering amazingly clear sound, long range and maximum voice security.

DECT operates on the 1.8Ghz frequency which eliminates potential interference from other common wireless devices such as cordless telephones, wireless networks (Wi-Fi), Bluetooth and cordless computer devices.

Pack Contents

- Parent unit (receiver)
- Baby unit (sender)
- Mains adaptor with charger pod
- NiMH rechargeable battery pack (2.4V,750mAh)
- Mains adaptor with power cord

Installation

For the Parent Unit

1. Remove the Belt Clip by lifting the clip at the top and sliding it downwards.
2. Then remove the battery cover on the back of the Parent Unit by pressing and sliding it downwards.

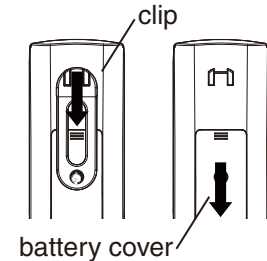

Note:

Observe the correct polarity and direction of the battery pack when inserting. The black lip of the battery pack must be facing downwards as illustrated. The unit will not operate if the battery pack is inserted incorrectly.

3. Insert the rechargeable battery pack (supplied) as illustrated and close the battery cover again.
4. Place the Parent Unit into the Charger Pod.
5. Plug the mains adaptor into a mains power socket.



The red charger light on the charger pod will illuminate indicating that the Parent Unit is charging.
(the light will remain on to ensure optimum charge is maintained).

4 GETTING STARTED

- 6 Press [] to turn the Parent Unit on.
 - Before first use, or if it has been out of use for a long time, the Parent Unit will need to be charged for 16 hours before use. After this time, the Parent Unit will operate from the Charger pod when switched on. Note that the Parent Unit cannot be used without a battery pack, even if it is placed in the charger.

For the Baby Unit

- 1 In the event of a power failure, your Baby Monitor can switch to battery power. It is therefore recommended that you insert non-rechargeable batteries in the Baby Unit.
- 2 Remove the battery cover on the back of the Baby Unit by pressing and sliding it down. Insert 3 alkaline batteries of the type AA (not provided) as marked on the unit and close the cover again. Do not use rechargeable batteries in the Baby Unit.
- 3 Plug the power cord into the power input at the side of the Baby Unit and plug the adaptor plug into a mains power socket.

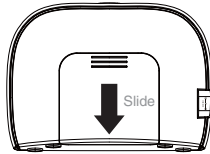

- 4 Press [] to turn on the Baby Unit.
 - The Baby Unit should be placed about 1 metre to 1.5 metres away from the baby's cot on a flat surface. Never place the Baby Unit inside the cot, bed or playpen. Make sure the unit, cords and mains adaptor are out of reach of the baby and other young children. Never place either Unit on antique or polished surfaces (as slippage or scuffing may occur). The unit may cause harm if it falls onto baby or other young children.

Note:

If you place the Parent and Baby units too close together you will hear a high pitched noise called "feedback", this is normal. The units are designed to be located in separate rooms.

To prevent feedback, do not take the parent unit into the nursery/baby's room.

Baby unit (Sender)

1 Night light Key

Press to turn On the night light. Press again to turn off the Light.

2 Power On/Off Key

Press to turn the Unit ON.

Press and hold to turn the Unit OFF.

3 Page Key

Press and hold this key, Parent unit makes an audible alert.

Useful to call for assistance or to locate a missing Parent Unit.

4 Power light

Red light glows when the power is On. A slow flashing light indicates batteries are low.

5 Microphone

Picks up the sounds from your baby's room.

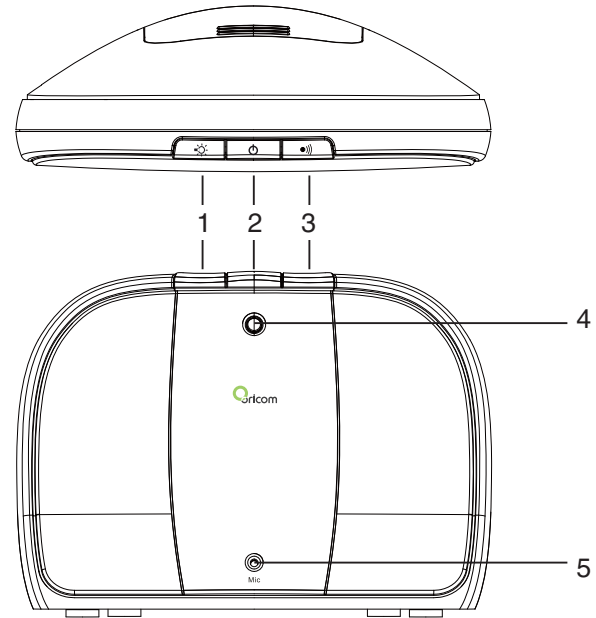

6 YOUR BABY MONITOR

Left view of baby unit

6 DC 6V input

Connecting to Power Adaptor.

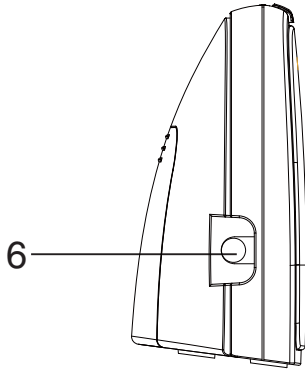

Parent unit (Receiver)

7 Battery Cover

Rechargeable battery pack.

8 Belt Clip

9 Volume Up/Down Keys

Adjust the Volume at which you hear the sounds in your baby's room.

10 Power Key

Press and release to turn it ON.

Press and hold to turn it OFF.

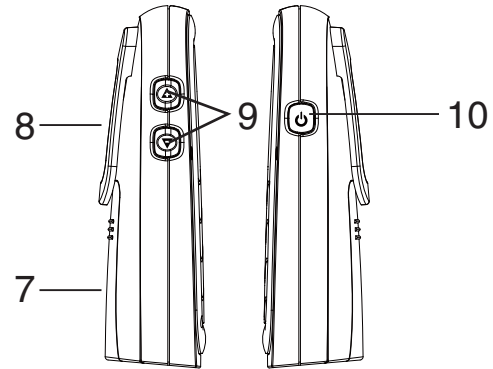

11 Power Light

Red light when the power is ON.

Flashing light indicates rechargeable battery needs recharging.

12 Battery/Noise Level Indicators

Indicates the battery level or Noise level

13 Link Light

Green light ON indicates “Linked” to Baby Unit. Flashing light indicates “Link” is lost.

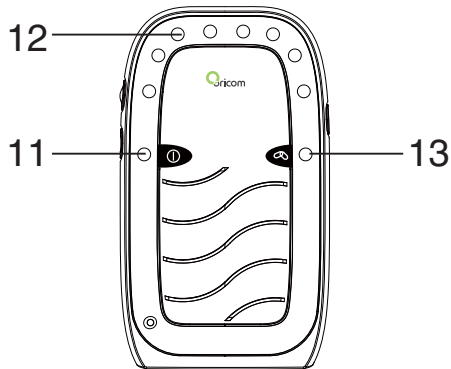

Charger Pod

14 Charging Light

When Parent unit is placed in the Charger Pod, the red charger light comes ON to indicate the battery is charging. Light will remain ON to ensure optimum charge is maintained.

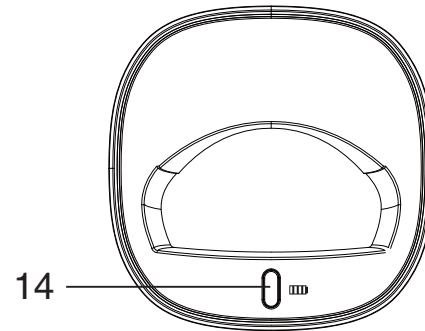

8 BASIC OPERATION

Once you have set up your Baby Monitor, you will be able to hear the sounds in your baby's room through the Parent Unit. And also see the green and red sensor lights around the top of the Parent Unit rise and fall with the sound levels.

Note:

If the connection between the Parent and Baby Units is broken at any time the green Link light on the Parent Unit will flash slowly, the parent unit will beep to alert you that the link has been lost and the green and red sensor lights will cease to react to any sounds. Move closer to the baby unit or follow the directions in "Troubleshooting" chapter to re-establish the link.

Power On/Off

Once connected to the power supply,

- Press [⏻] on each Unit to turn on the power.
- To switch off, press and hold the [⏻].

Monitoring

- Position the baby unit accordingly. It should be placed 1 metre to 1.5 metres away from the baby's cot on a flat surface.
- Take the parent unit to monitor.
- Audio picked up by the baby unit microphone is depicted on the 8 lights on the parent unit (5 green

and 3 red). The more audio is picked up, the more lights will be lit. When no audio is picked up, all 8 lights will be off.

- If the volume of the Parent Unit is turned off, an alert will sound when the audio reaches the second red led.

Note:

Do not position the baby unit and the parent unit close to each other as feedback may be generated.

Adjusting Volume

You can adjust the volume at which you hear your baby.

There are 5 volume levels and an Off setting on the Parent Unit.

Press [▲] to increase the volume and [▼] to decrease the volume. When adjusting the volume, the 5 green sound sensor lights will illuminate to indicate the volume level.

Paging

If the Parent Unit is misplaced, you can use [🔊] button on the Baby Unit to locate the Parent Unit.

- Press and hold [🔊] on the Baby Unit. The Parent Unit will automatically reset to mid volume and the paging alert will sound.

- To stop the Page alert, press any button on the Parent Unit, or press [•»] again on the Baby Unit.

Note:

If no button is pressed, the paging tone will stop after 2 minutes.

If the Parent Unit volume is off, the Parent Unit volume will reset to mid volume.

Night light

The Baby Unit has a one touch night light which emits a soft starry glow, providing comfort and reassurance for your baby and allowing you to see them in a darkened room.

Press [•ö] on the top of the baby unit. A soft light will turn on gently. Press again and the light will fade away.

Out of Range

When the baby and parent units have no link with each other (eg. Out of range, parent unit or Baby unit is not powered on), the green Link light flashes. The link break alert will be heard from the Parent Unit every 30 seconds. When the units are linked, the green Link light will be steadily lit.

Low Battery

Baby Unit

When the battery power is low, the power light will flash.

Parent Unit

When the battery is low, the red power light will flash. And also the battery low warning beep will be heard. The unit still can be used for 30 minutes. You should put the parent unit on the charger pod to recharge the battery.

Note:





Low battery alert can be suppressed by pressing any button.

Charging the Battery

Depending on usage the Parent Unit will work for up to 10 hours with a fully charged battery. If a battery low warning beep is heard and the red Power light on the Parent Unit is flashing, you should put the parent unit on the Charger Pod to recharge the battery. You can still use your Parent Unit from the Charger Pod. When charging, the red power light on the charger will light steadily.

When you switch on your Parent Unit, the green and red sensor lights will briefly indicate the current charge level of the battery in the following way:

10 BASIC OPERATION

8 lights illuminated		fully charged
6 lights illuminated		half charged
4 lights illuminated		battery is running low
2 lights illuminated (alarm beep sounds)		battery needs recharging

Note:

The parent unit can be used on or off the charger pod. When on the charger pod, the battery will be recharged at the same time. However, the time it takes to charge the battery to full will be longer when the unit is charged and used at the same time.

The Parent Unit can't be operated on the charging cradle without a battery.

Running the rechargeable battery right down at least once a week will help it last as long as possible. The charge capacity of a rechargeable battery will reduce with time as they age, so reducing the performance time of the parent unit. Eventually they will need to be replaced.

TROUBLESHOOTING 11

Problem	Possible cause(s)
The red power lights do not turn on when you plug in the power.	<ol style="list-style-type: none"> 1. Check if the units are properly connected to the power supply. 2. Check if the power is turned on. If not, Press [⏻] to turn on the power.
The green Link light on the Parent Unit is flashing and cannot hear the sounds from your baby's room.	<ol style="list-style-type: none"> 1. You may have moved out of range. Move closer to the Baby Unit and wait 5 seconds for the Link to establish. 2. You may need to re-establish the Link between the two units. Turn both units off by pressing and holding the [⏻] and then turn on again by pressing the [⏻].
Can't hear your baby on the Parent Unit but the Link light is still glowing steadily.	Check if the volume is turned up on the Parent Unit.
The Red Power light is flashing on the Parent Unit	Your re-chargeable battery is running low. Return the Parent Unit to the Charger Pod to recharge it.
Two bars flash on the parent unit.	<ol style="list-style-type: none"> 1. The battery in the parent unit is not fully charged. Charge the parent unit for 14 hours before use. 2. The power to the baby unit may be turned off or disconnected, and or the Baby unit may be turned off. Reconnect the AC power adaptor to the baby unit and or turn on the baby unit. 3. You may have to re-establish the link between the two units. You will need to remove the battery from the parent unit and register the parent unit back to the baby unit by following the instructions below: <ol style="list-style-type: none"> A. Ensure battery is removed from the Parent unit (and baby unit if fitted) and the AC power plug is disconnected from the Baby unit). Press and hold the [⏻] on the BABY unit then plug in the AC power plug, after 2 seconds, when the baby unit night-lights flash release the [⏻] button; B. Press and hold the [⏻] on the PARENT unit then insert the battery, after 2 seconds, the parent unit will sound an alert and the level indication red LED's will flash, then release the [⏻] button; C. After a few seconds, the PARENT unit will give a confirmation tone and the units will be re-linked and ready to use. <p>NOTE: Steps A and B need to be performed within 50 secs.</p>
A high pitched ear piercing noise will be heard from the units (feedback).	Check if the Parent and Baby Units are too close together. Move them further apart.

12 PRODUCT SPECIFICATIONS

Feature	Specifications
Operating Frequency	DECT 1.8 GHz
Range	Up to 300m under optimum conditions. The range is reduced in buildings (up to 50m) as a result of walls, doors etc.
Power supply (baby unit)	Input: 100~240 V _{AC} 50/60Hz Output: 6 V _{DC} , 500 mA,
Non rechargeable batteries (baby unit) (not included in the package contents)	Type: AAA, 1.5 V Alkaline
Transmitting power	Average: 10 mW Maximum: 250 mW
Power supply (parent unit)	Input: 100~240 V _{AC} 50/60Hz Output: 7 V _{DC} , 420 mA
Rechargeable battery pack (parent unit) (included in the package contents)	Type: 2.4V, 750mAh Ni-MH
Operating time with charged battery	Approx. up to 10 hours

Customer Support

If you have any problems setting up or using this product you will find useful tips and information in the Troubleshooting section of this user guide as well as “Frequently Asked Questions” on our website www.oricom.com.au.

If you have further questions about using the product after reviewing the resources above or would like to purchase replacement parts or accessories please call our Customer Support Team. Our dedicated local support team are more likely to be able to help you than the retailer where you made your purchase.

Important

Please retain your purchase receipt and attach to the back page of this user guide as you will need to produce this if warranty service is required. Take a few moments to register your product online: www.oricom.com.au

How to make a claim under Warranty in Australia

Oricom has a simple warranty process for you to follow:

- Please call or email our Customer Support Team, contact details follow.
- A Customer Support Team member will verify after troubleshooting with you if your product qualifies under warranty. If so, they will give you a Product Return Authorisation number.
- We will then email or fax a Return Authorisation form and a Repair Notice (if necessary), together with instructions on how to return the goods for warranty service.

Please note that if a Customer Support Team member advises that your product does not qualify for return, this warranty does not apply to your product.

Products that are authorised to be returned to Oricom in Australia must include all of the following:

- A completed Return Authorisation form
- A copy of your Proof of Purchase (please keep your original copy)
- The faulty product, including all accessories.

Send the approved returns to:

Oricom International Pty Ltd

Locked Bag 658

South Windsor NSW 2756 Australia

Please note that this warranty excludes expenses incurred by you in returning any faulty product to us. You must arrange and pay any expenses incurred (including postage, delivery, freight, transportation or insurance of the product) to return the faulty product to us, however, we will arrange delivery of the repaired or replaced faulty product to you.

Important Information

Repair Notice

Please be aware that the repair of your goods may result in the loss of any user-generated data (such as stored telephone numbers, text messages and contact information). Please ensure that you have made a copy of any data saved on your goods before sending for repair.

Please also be aware that goods presented for repair may be replaced by refurbished goods or parts of the same type rather than being repaired.

14 GUARANTEE

Warranty Information (Australia)

This Warranty is provided by Oricom International Pty Ltd ABN 46 086 116 369, Unit 1, 4 Sovereign Place, South Windsor NSW 2756, herein after referred to as “Oricom”.

Oricom makes no other warranties or conditions, express or implied, including as to acceptable quality and fitness for a particular purpose, except as stated in this Warranty.

Any implied warranties that may be imposed by law are limited in duration to the Warranty Period.

Oricom warrants that the product is free from defects in materials or workmanship during the Warranty Period. This Warranty does not extend to any product from which the serial number has been removed or was purchased outside of Australia.

This warranty in no way affects your statutory warranty rights under the Competition and Consumer Act 2010 or any other similar legislation.

The Warranty Period will be 3 years from the date of purchase of the product evidenced by your dated sales receipt. You are required to provide proof of purchase as a condition of receiving warranty services.

You are entitled to a replacement product or repair of the product according to the terms and conditions of this document if your product is found to be faulty within the Warranty Period. This Warranty extends to the original purchaser only and is not transferable.

Rechargeable battery cells and rechargeable battery packs (if supplied) with this product are covered under this warranty for a period of 90 days.

Products distributed by Oricom are manufactured using new materials or new and used materials equivalent to new in performance and reliability. Spare parts may be new or equivalent to new. Spare parts are warranted to be free from defects in material or workmanship for thirty (30) days or for the remainder of the Warranty Period of the Oricom branded product in which they are installed, whichever is longer. During the Warranty Period, Oricom will where possible repair and if not replace the faulty product or

part thereof. All component parts removed under this Warranty become the property of Oricom. In the unlikely event that your Oricom product has a recurring failure, Oricom may, subject to the Competition and Consumer Act 2010, at its discretion, elect to provide you with a replacement product of its choosing that is at least equivalent to your product in performance.

Oricom does not warrant that the operation of the product will be uninterrupted or error free.

Oricom is not responsible for damage that occurs as a result of your failure to follow the instructions that came with the product. These terms and conditions together with any specific terms and conditions contained in the user guide to the product purchased constitute the complete and exclusive agreement between you and Oricom regarding the product.

No change to the conditions of this Warranty is valid unless it is made in writing and signed by an authorised representative of Oricom.

Oricom will not be in breach of a warranty expressly set out in this User Guide or under the Competition and Consumer Act 2010 and excludes any liability for damages or any other remedy arising under any other legislation or the common law if the damage occurs as a result of:

1. failure by you to adhere to the warnings and follow the instructions set out in this user guide for the proper installation and use of the product;
2. negligence on your part or misuse by you of the product;
3. an uncontrollable external cause which results in the product not functioning including but not limited to power failure, lightning or over voltage; and
4. modification to the product or services carried out on the production by anyone other than Oricom or Oricom's authorised service provider.

Oricom will not be liable for any damages caused by the product or the failure of the product to perform, including any lost profits or savings or special, incidental or consequential damages. Oricom is not liable for any claim made by a third party or made by you on behalf of a third party. This limitation of liability applies whether damages are sought, or a claim made, under this Warranty or as a tort claim (including negligence and strict product liability), a contract claim or any other claim. However, this limitation

of liability will not apply to claims for personal injury. Nothing in this Warranty excludes, restricts or modifies any condition, warranty, right or remedy which pursuant to the Competition and Consumer Act 2010 applies to this Warranty and which may not be so excluded, restricted or modified. For warranties that cannot be excluded, restricted or modified, Oricom limits the remedies available to those specified in the relevant legislation.

Oricom products come with guarantees that cannot be excluded under the Australian Consumer Law. You are entitled to a replacement or refund for a major failure and compensation for any other reasonably foreseeable loss or damage. You are also entitled to have the goods repaired or replaced if the goods fail to be of acceptable quality and the failure does not amount to a major failure.

Contact details for Oricom support and warranty claims in Australia

Oricom International Pty Ltd
Locked Bag 658
South Windsor, NSW 2756
Australia

Email: support@oricom.com.au
Phone: 1300 889 785
(Monday to Friday 8am to 6pm AEST)
Web: www.oricom.com.au
Fax: (02) 4574 8898

Contact details for Oricom support and warranty claims in New Zealand

Email: support@oricom.co.nz
Phone: 0800 674 266
(Monday to Friday 10am to 8pm NZST)
Web: www.oricom.co.nz

