



Baby Monitor Secure 850



User Guide

KEEP THIS USER GUIDE FOR FUTURE REFERENCE

Always retain your proof of purchase in case of warranty service.
AUSTRALIA: www.oricom.com.au

TABLE OF CONTENTS

SAFETY INFORMATION	1
OVERVIEW OF FUNCTIONAL COMPONENT POSITIONS	3
GETTING STARTED	5
USING THE BABY MONITOR	8
TROUBLE SHOOTING	13
EXPRESS WARRANTY	16

Need Help?

If you need assistance setting up or using your Oricom product now or in the future, call Oricom Support.

Australia 02 4574 8888
 www.oricom.com.au
 Mon-Fri 8am – 6pm AEST

New Zealand 0800 67 42 66
 www.oricom.co.nz
 Mon-Fri 10am – 8pm NZST

1 Important Safety Information

- It is very important that you read the User Guide carefully as it contains detailed information you will need to get the most from your Oricom baby monitor. If you have any issues setting up or using your Oricom baby monitor please call our Customer Support team. Our dedicated local team are more likely to be able to help you than the retailer where you made your purchase.
- **Your Oricom baby monitor is designed to be an aid and should not be used as a substitute for responsible and proper adult supervision of a child.**
- The baby monitor has been designed to provide some added reassurance in the form of sound transmission for those times when you are not in the same room as your baby provided you always stay within hearing range of the baby monitor during use. Your baby monitor is not a medical device, nor a device to prevent cases of Sudden Infant Death Syndrome (SIDS) or "cot death", and you should not rely on it for your baby's wellbeing. It is important that you regularly check on your baby personally.
- Make sure the baby unit, parent unit and mains adaptor cables are kept out of reach of your baby and other young children at all times, at least one metre away.
- Never place the baby unit or parent unit inside your baby's cot, bed or playpen.
- Never cover the parent or baby units with clothes, towels or blankets or any other item. Never use or place your parent or baby unit in or near moisture or water (e.g. near bath or pool). Immersing in water could cause electric shock and even death.
- The installation location plays an important role in ensuring proper operation. Therefore, maintain a distance of at least one metre from other electronic equipment, such as microwave ovens or hi-fi devices, otherwise they could cause interference. During continual use the baby unit power adaptors may become warm to the touch. This is normal and should not be a concern.



Warning

Risk of suffocation!
Keep all packaging materials and protective foils out of reach of children.

2 SAFETY INFORMATION



Warning

Do not place the AC Adaptor cable in a high "wear and tear" location. Never use a frayed or compromised cord.

Battery safety

- Batteries represent a hazard to health and the environment!
- They contain toxic, ecologically hazardous heavy metals. Do not dispose of batteries in a fire as they may explode. Dispose of batteries according to local regulations, never in your household rubbish.
- Do not dismantle, cut, open, crush, bend, puncture, or shred cells or batteries. If a battery leaks, do not let the battery liquid touch skin or eyes. If this happens, immediately flush the affected areas with water, and seek medical assistance.
- Do not modify, remanufacture, attempt to insert foreign objects into the battery, or immerse or expose it to water or other liquids. Batteries may explode if damaged.
- Use only the battery supplied with the product. Improper use, or use of unapproved batteries may present a risk of fire, explosion, or other hazard, and may invalidate any approval or warranty.
- If you believe the battery is damaged, remove product from the charger and stop using the product. Contact Oricom for assistance. Never use a damaged battery.

Disposal

Always dispose of your products at the end of their life in accordance with your local waste disposal requirements.

Packaging materials all cardboard and paper packaging should be recycled in accordance with your local council waste regulations.

2 Overview of your Baby Monitor

Your Parent Unit

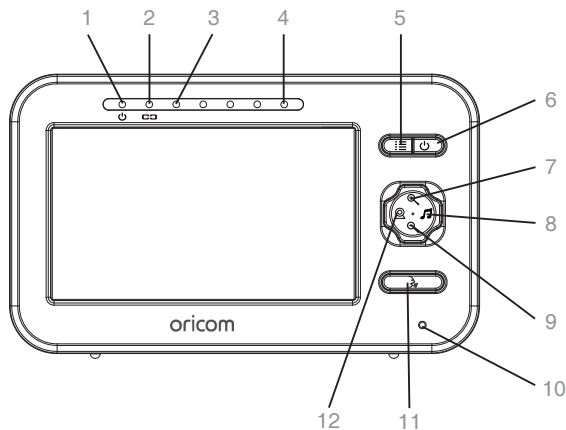

- | | |
|-------------------------------------|---|
| 1 Power LED | 8 Play/Stop
(Select Melody) |
| 2 Link LED | 9 Volume Down
(Down Arrow) (x1 Zoom) |
| 3 Lowest level | 10 Microphone |
| 4 Highest level | 11 Push To Talk |
| 5 Menu (Pan/Tilt) | 12 Change CAM#
Register CAM |
| 6 Power (Video) on/off | |
| 7 Volume Up
(Up Arrow) (x2 Zoom) | |

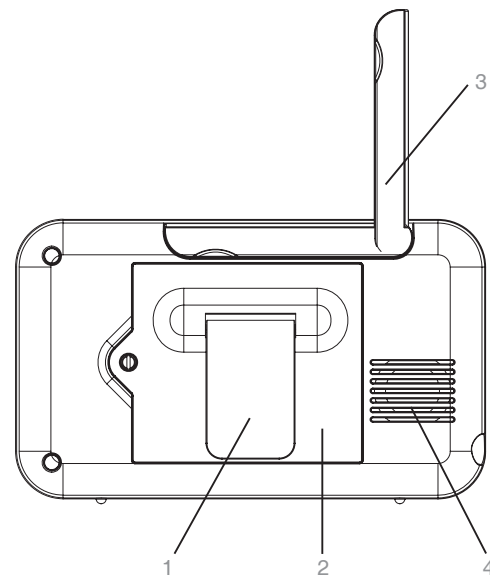

- | |
|-----------------------|
| 1 Stand |
| 2 Battery compartment |
| 3 Antenna |
| 4 Speaker |

4 OVERVIEW OF FUNCTIONAL COMPONENT POSITIONS

Your Camera Unit

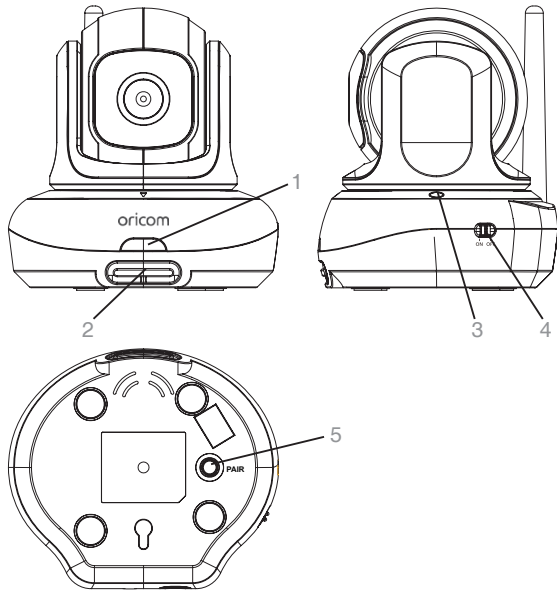

- 1 Night Light
- 2 Speaker
- 3 Light Sensor
- 4 Power
- 5 Pair

Check pack contents

This pack should contain:

- 1 camera / baby unit
 - 1 parent unit
 - 1 Li-ion Polymer rechargeable battery pack for the parent unit
 - 1 AC adaptor for the parent unit
 - 1 AC adaptor for the baby unit
- If any items are missing contact Oricom customer support

3 GETTING STARTED

3.1 Baby unit power supply

- (1) Connect the small plug of the power adaptor to the baby unit and the other end to the electrical mains power outlet.
- (2) Switch the unit to the ON position. The power LED will light up.
- (3) To switch off the baby unit, slide the power switch to OFF position.



Warning

Only use the AC power adaptor supplied with the product as other power adaptors could damage the product. This product is designed for indoor use only.

3.2 Connecting and aligning the baby unit

Position the baby unit with a minimum distance of 1m to other electronic devices, otherwise there is a risk of mutual disturbance. Point the upper section of the baby unit towards the baby or object you want to monitor. Check that the baby or object is suitably displayed on the parent unit screen. Ensure the antenna is extended vertically for optimum range.

3.3 Parent unit battery installation

- (1) Insert the battery pack into the parent unit ensuring the contacts match.

- (2) Close the battery compartment.
- (3) Press and hold <Power> key for 2 seconds to switch on the parent unit. It will take a few seconds for the unit to start up. The power LED will light up.
- (4) If press and hold <Power> key for 2 seconds again to turn OFF the parent unit.

NOTE:

When the battery level is low, the power LED will flash slowly.

3.4 Charging the Parent unit

- (1) Connect the small plug of the power adaptor to the parent unit and other end to the electrical mains power outlet.
- (2) If the unit is powered off, the power LED will turn on steadily.
- (3) If the unit is powered on, the battery level indicator will change to indicate the battery charging status.

NOTE:

YOU MUST INITIALLY CHARGE THE BATTERY FOR 12-14 HOURS BEFORE USE. THIS IS IMPORTANT TO MAINTAIN ADEQUATE BATTERY PERFORMANCE.

6 GETTING STARTED

IMPORTANT



The parent unit is powered by a rechargeable Lithium Battery Pack. The amber Power LED lights up on the parent unit when it is in the charger to indicate power is being supplied to the unit. In the case of a low battery the amber Power LED will flash. The parent unit should be returned to the cradle to recharge. The amber light will always be lit when the parent unit is in the charging cradle.

Switching the Baby Unit ON/OFF

Position the baby unit in a good position for the monitoring task required and align the camera lens to the area to be monitored.

 Slide the switch to ON, the Power LED lights up. The baby unit is now ready to operate.

 To switch the unit off, slide the switch to OFF.

In-use time and battery charging

Depending on the usage the parent unit will work for up to 8 hours on a fully charged battery with the VOX feature turned ON.

When the battery charge becomes low on the parent unit the amber power LED will flash slowly. At this point you need to connect the parent unit to the charger.

When charging, the battery status indicator on the parent unit screen will change to the charging icon  .

To speed up the charging process, turn the parent unit off when charging if it is not being used.

You can continue to use your parent unit to monitor your baby even when the battery is low, provided it remains on the charger to recharge the battery.

NOTE:

- The parent unit can be kept on the charger even if it is fully charged. This will not affect the battery life.
- The parent unit can be used on or off the charger.
- When the parent unit is being used while on the charger.
- We recommend that you TURN OFF the parent unit when it is not in-use, to conserve battery power.

Battery Life

The rechargeable battery pack (supplied) can be charged and discharged hundreds of times, however they will eventually wear out and lose their ability to hold a full charge. When the in use time becomes noticeably shorter than normal, it is time to purchase a new battery pack.

How to purchase spare parts

You can purchase Battery packs (Model No: BPCCK1700LI) chargers and extra camera units from www.oricom.com.au

Extra Charging Cradles

For added convenience you may wish to purchase additional chargers online at www.oricom.com.au.

Optimisation of Range

The parent unit has a fold out antenna, extend the antenna vertically to achieve optimal range from your monitor.

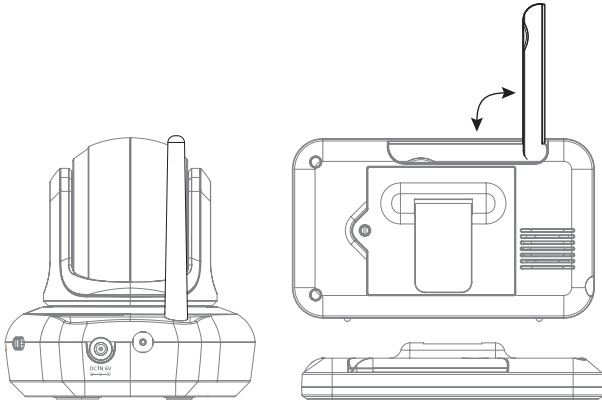

4 USING THE BABY MONITOR

Once the baby and parent units are switched on, the display on the parent unit will show the video captured by the baby unit.

4.1 Switching on the parent unit

Press and hold the power button until the Oricom logo appears on the parent unit. The camera image will then appear.

Press and hold the power button for approx. 1 second to switch the unit off.

NOTE:

If you place the Parent and Baby units too close together you will hear a high pitched noise called “feedback”, this is normal. The units are designed to be located in separate rooms.

To prevent feedback, do not take the parent unit into the nursery/baby’s room.

Do not press the talk button when the baby unit and parent unit are positioned in the same room. Feedback will be generated if the talk button is pressed when the baby unit and parent unit are close to each other.

4.2 Talk function

- (1) Press and hold <Push to Talk> button on the parent unit to talk to your baby through the baby unit loudspeaker. The talk symbol will be displayed in the middle of the LCD screen.

NOTE:

The lullaby will stop playing if the Talk function is activated.







4.3 Adjusting the volume of the parent unit

Press <▲> and <▼> to adjust the volume of the parent unit.

[] appears on the LCD screen. There are 5 levels can be adjusted.

4.4 Playing a lullaby for your baby

You can remotely activate a lullaby to be played on the baby unit

- (1) Press and release <Music> button on the parent unit to play the previous lullaby and [ X] appears on the LCD screen.
- (2) When the music starts playing, within 8 sec, press <▲> and <▼> keys to change lullabies. There are 5 lullabies available for selection, indicated by [ 1], [ 2], [ 3], [ 4] and [ 5].
- (3) Press < Music > again to stop.
- (4) If you want to change to a different lullaby in the middle of playing music, it is necessary to turn the music off, then turn on again to resume (the music will change within 8 seconds).

4.5 Out of range indication

When the distance between the parent unit and baby unit is too far, [Out of Range] will display on the parent unit and the

link LED will flash. Move the parent unit closer to the baby unit until the link is re-established. Both the parent unit and baby unit antennas should be extended vertically to achieve the best range.

4.6 Infrared Sensitive Night vision

The camera has high-intensity infrared LEDs for picking up clear images in the dark. When the built-in light sensor detects a low level of ambient light, the LEDs will automatically activate and the screen on the parent unit will display in black and white.

4.7 Brightness

- (1) When unit is in monitor mode or stand-by status, press <Menu> once [] appears on the LCD screen.
- (2) Press <▲> and <▼> to adjust the LCD brightness level to 1, 2, 3, 4 or 5.
- (3) Press <Menu> button to confirm the selection. And press <Menu> several times until no menu icon showing on LCD, ie. back to monitor mode.

4.8 Temperature Display (°C)

- (a) You can set the high / low temperature warning trigger values as following:
 - (1) Press <Menu> repeatedly to go to [Lo], then press <▲> and <▼> to change the values to set low temperature trigger point.

- (2) Press <Menu> key several times to back to monitor mode or just short press power key once to save the value.
- (3) Similarly, press <Menu> key to go to [Hi] to set the high temperature trigger point.

(b) Turn temperature alert off

The alert beep tone can be turned off :

- (1) If user presses <▲> key to set Hi temp alert value, after reaches a pre-defined value, then the alert tone becomes OFF. eg. 28→29→30→OFF.
- (2) If user presses <▼> key to set Low temp alert value, after reaches a pre-defined value, then the alert tone becomes OFF. eg. 19→18→17→OFF.

This Highest and Lowest temperature alert values are set during manufacture.

The Temperature sensor used in this Oricom baby monitor is intended as a guide, to provide parents with an indication of the room temperature in which the baby unit has been placed.

NOTE: If the temperature alert function is turned on:

1. If the temperature goes above 27°C, [Hi] appears on the LCD display: A warning beep will be transmitted periodically until the temperature returns to mid-range.
2. If the temperature goes below 19°C, [Lo] appears on the LCD screen. A warning beep will also transmit periodically until the temperature returns to mid-range.

10 USING THE BABY MONITOR

4.9 Night Light

- (1) Press <Menu> repeatedly until [Moon] icon appears on the LCD screen.
- (2) Press <▲> and <▼> to turn the baby unit night light ON or OFF.
- (3) Press <Menu> button to confirm the selection. And press <Menu> several times until no menu icon showing on LCD, ie. back to monitor mode.

4.10 Voice Activation

The sound detection sensitivity level (VOX) of the baby monitor can be adjusted. If the baby is a quiet sleeper, the sensitivity level can be increased so that minor disturbances can be detected and transmitted to the parent unit.

- (1) Press <Menu> repeatedly until [**VOX** ] appears on the LCD screen or OFF.
- (2) Press <▲> and <▼> to adjust the VOX level to 1, 2, 3, 4, 5 or OFF.
- (3) When the VOX function is on (level 1 to 5), the LCD screen will switch off after a 1 min if the detected sound is below the level selected.
- (4) Press <Menu> button to confirm the selection. And press <Menu> several times until no menu icon showing on LCD, ie. back to monitor mode.

NOTE:

1. Level 5 is the most sensitive and so will need to be the quietest before the LCD will switch off.

2. The LCD screen on the parent unit will be switched back on when the sound level of the baby reaches the VOX threshold or when any key on the parent unit is pressed.

4.11 Zoom Mode

- (1) Press and hold <Volume Up> key for 2 seconds in order to enter x2 zoom mode. The live viewing area will change to x2 zoom mode immediately. A x2 magnification icon appears in the centre of the screen for approx. 8 sec. A x2 icon appears in the top status bar.
- (2) Press and hold <Volume Down> key for 2 seconds in order to exit x2 zoom mode. The live viewing area will change to x1 zoom mode immediately. A x1 magnification icon appears in the centre of the screen for approx. 8 sec. The x2 icon disappears in the top status bar.

Mechanical pan/tilt

- (1) Press <Menu> key once in order to enter pan/tilt mode. Four direction arrows are displayed at the middle of the screen.
- (2) Press <▲> and <▼> to move the screen up and down.
- (3) Press <Camera> key to move the screen to left.
- (4) Press <Music> key to move the screen to right.
- (5) The PU will exit the pan/tilt mode if no key is pressed for a while. Then none of direction arrow icon appears.

- (6) User can also press <Menu> button once to exit the pan/tilt mode.

4.12 Selecting a Camera Channel or scan

(a) Select Camera Channel

- (1) On monitor mode, press and release [Camera] key, currently viewing camera number will prompt out.
- (2) Press and release [Camera] key again, then it will switch to next registered camera unit from 1 to 4 and scan mode.
- (3) It only switches to registered camera number, for example, if two camera units are registered to cam 1 and cam 2, then every short press the key will go to cam 1 → cam 2 → scan → cam 1 again.
- (4) Press <Menu> button to confirm the selection.
- (5) In each of the four camera channel, you can set all other features individually.
- (6) If only one camera registered, then short press this key will no response.

(b) Scan Mode operation

- (1) This function only turns on video for channels that camera/s have been registered to.
- (2) When switching to view each camera by <Camera> key, there is a checked mark next to camera icon.
- (3) This checked mark can change to cross mark by using Up / Down arrow keys. It means the camera is being turned off on scan mode.
- (4) All cameras are possible to turn on or off individually.

- (5) It is also effective not only in scan mode function, but also applies to single camera view mode. In other words, if you switch to that camera channel, you must turn that video to on by <Up> arrow key as well.
- (6) When you switch back to single camera and VOX mode is not selected during Scan mode the camera will resume to the previous VOX setting status.

4.13 Video ON/OFF (Only audio monitor mode)

(a) User can turn off the screen but continue to hear background sound from camera unit

- (1) During video monitor mode, press and release <⏻> key, LCD is then turned off and receives sound from camera (ie. only audio monitor mode).
- (2) Speaker is always on during audio monitor mode but VOX status is depending on user setting. If VOX set to ON, then LCD will triggered to turn on by camera sound level. If VOX set to OFF, then LCD must be turned on by user pressing any key.
- (3) User also can turned video on by pressing any key.
- (4) If the unit is in scan mode when the screen is turned off, the unit will keep scanning each camera in the background. You will hear background noise dependant on which camera is being scanned.

(b) Optional setting as quick enter to VOX mode

When unit is off, press the on/off button (⏻) once to turn on the unit. If unit is on, press and hold the on/off button (⏻) key for 2 sec, the unit is powered off.

12 USING THE BABY MONITOR

The On/off (⏻) button also activates VOX mode by pressing the button once during video monitor mode. The unit then goes to VOX mode immediately without waiting for 1 minute silent. After the unit enters VOX model, you can press any key to turn the video on again.

4.14 Registration

The parent and baby unit are pre-registered. If necessary (for example, buy an extra camera), registration can also be completed manually: Up to 4 baby units can be registered to one parent unit.

To re-register your baby unit, or register a new baby unit, follow the procedure below:

- (1) Switch on the parent unit.
- (2) On monitor mode, press and hold <Camera> key for 5 seconds, it will go to registration mode.
- (3) After registration icon [📺] comes up on screen, press <▲> or <▼> to select the camera channel [C1] or [C2] or [C3] or [C4] that you want the baby unit to pair with.
- (4) Press and release <Menu> key to confirm which camera number to be registered.
- (5) The Link LED then flashes rapidly for 10 seconds.
- (6) Switch the baby unit ON. Press the pair key once (at the back of the camera).

- (7) If registration is completed, camera video appears on LCD screen and return to normal mode. Baby unit will return to normal mode too.
- (8) If the registration time is expired or registration is failed, [Out of Range] appears on LCD. Should this occur, please attempt the registration process once more.

NOTE:

If a particular channel had been registered already, register this particular channel again will over-write the old registration.

5 Troubleshooting

Should you experience difficulties operating the SC850 please refer to the troubleshooting guide below. If you still experience difficulties please contact Oricom Customer Support on (02) 4574 8888 for assistance.

Troubleshooting

Problems	Solutions
Equipment does not function	<ul style="list-style-type: none"> - Check both parent unit and baby unit are turned on Check parent unit is charged or plugged into charger Check baby unit is connected to power.
“Out of Range” displaying on parent unit	<ul style="list-style-type: none"> - Move the parent unit closer to the baby unit. Try resetting your monitor to avoid busy channels: <ol style="list-style-type: none"> 1. Turn both Camera and Parent units off and remove the battery in the parent unit. Leave unplugged for 5mins. 2. If you have Wi-Fi in the home, make it busy by streaming a video on YouTube or similar. 3. Turn the camera back on wait for 30 seconds. 4. Ensure the antenna on both the parent unit and camera unit is in the vertical position. 5. Plug the battery into the parent unit and turn on. <p>If the display is still showing “Out of Range” please re-register the units as instructed on page 8. When re-registering it is best to keep the camera and parent units close together (within 1m) and keep clear of all other electronic devices including mobile phones, tablets or computers.</p>
Reception interference	<ul style="list-style-type: none"> - Move the parent unit closer to the baby unit. Reposition the baby unit slightly. Check for interference from other electronic devices such as Wi-Fi.
High pitched noise from parent unit - Feedback	<ul style="list-style-type: none"> - Increase the distance between the parent unit and baby unit. Reduce the volume on the parent unit.

14 TROUBLESHOOTING

Amber power LED flashing	- The battery level is low. Return the parent unit to the charger.
Picture but no sound	- Increase the volume on the parent unit.
Picture is in black and white	- Night function is active. Increase the light level in the baby's room if required.
Picture on parent unit not displaying correctly	- Switch off parent unit then camera unit. Wait 10 seconds. Switch on the camera unit then parent unit (in that order).
Battery not charging	- Check the battery is connected to the battery connection in the battery compartment. - After a period of time, the battery may need to be replaced due to everyday usage. Please visit www.oricom.com.au to purchase replacement batteries.
Parent unit beeping	Move the parent unit closer to the baby unit until they are within the range.
No picture after 10 seconds	VOX function is activated. Turn off VOX if required.
Picture changes every 10 seconds	Scan function is on. Turn off the scan function.

6 Technical Specifications

Technical data

Feature	Value
Camera (baby unit)	Socket: 5.9 V DC Sensor: 1 night light sensor IR diodes: 6pcs
Monitor (parent unit)	Screen: 4.3" LCD display Socket: 5.9 V DC
Battery Pack for Parent unit	Rechargeable Li-ion Polymer Battery pack 3.7V 1700 mAh
Power supply (parent unit)	AC Power adaptor, input: 100-240 VAC, 50-60Hz, 150 mA Power adaptor plug, output: 5.9 V DC, 800 mA

Battery performance	Up to 8 hours of continuous operation when new battery is fully charged, with VOX turned on.
Power supply (baby unit)	AC Power adaptor, input: 100-240 VAC, 50-60Hz, 150 mA Power adaptor plug, output: 5.9 V DC, 800 mA
Range	Up to 150 meters under optimum conditions. Range is reduced in buildings through walls, doors etc.
Frequency range	2.4 GHz Digital FHSS
Permissible ambient temperature	0°C to 40°C

Note

For a replacement battery pack or other spare parts please contact Oricom.

16 EXPRESS WARRANTY

Express Warranty (Australia)

This Express Warranty is provided by Oricom International Pty Ltd ABN 46 086 116 369, Unit 1, 4 Sovereign Place, South Windsor NSW 2756, herein after referred to as "Oricom".

Oricom products come with guarantees that cannot be excluded under the Australian Consumer Law. You are entitled to a replacement or refund for a major failure and compensation for any other reasonably foreseeable loss or damage. You are also entitled to have the goods repaired or replaced if the goods fail to be of acceptable quality and the failure does not amount to a major failure. Oricom warrants that the product is free from defects in materials or workmanship during the Express Warranty Period. This Express Warranty does not extend to any product from which the serial number has been removed or was purchased outside of Australia.

Nothing in this Express Warranty excludes, restricts or modifies any condition, warranty, guarantee, implied term, right or remedy pursuant to the Australian Consumer Law and which may not be so excluded, restricted or modified. For such conditions, terms, guarantees and warranties that cannot be excluded, restricted or modified, Oricom limits the remedies available to extent permitted in the relevant legislation.

The Express Warranty Period will be 3 years from the date of purchase of the product evidenced by your dated sales

receipt. You are required to provide proof of purchase as a condition of receiving Express Warranty services.

You are entitled to a replacement product or repair of the product at our discretion according to the terms and conditions of this document if your product is found to be faulty within the Express Warranty Period. This Express Warranty extends to the original purchaser only and is not transferable.

Products distributed by Oricom are manufactured using new materials or new and used materials equivalent to new in performance and reliability. Spare parts may be new or equivalent to new. Spare parts are warranted to be free from defects in material or workmanship for thirty (30) days or for the remainder of the Express Warranty Period of the Oricom branded product in which they are installed, whichever is longer. During the Express Warranty Period, Oricom will where possible repair and if not replace the faulty product or part thereof. All component parts removed under this Express Warranty become the property of Oricom. In the unlikely event that your Oricom product has a recurring failure, Oricom may always, subject to the Competition and Consumer Act 2010, at its discretion, elect to provide you with a replacement product of its choosing that is at least equivalent to your product in performance.

No change to the conditions of this Express Warranty is valid unless it is made in writing and signed by an authorised representative of Oricom.

Oricom will not be liable under this Express Warranty, and to the extent permitted by law will not be liable for any defect, loss, damage or injury arising out of or in connection with a:

1. Failure by you to adhere to the warnings and follow the instructions set out in this user guide for the proper installation and use of the product;
2. Wilful misconduct or deliberate misuse by you of the product;
3. Any external cause beyond our control, including but not limited to power failure, lightning or over voltage; or
4. Modification to the product or services carried out on the product by anyone other than Oricom or Oricom's authorised service provider.

18 EXPRESS WARRANTY

How to make a claim under your Express Warranty in Australia

Oricom has a simple warranty process for you to follow:

- Please call or email our Customer Support Team, (02) 4574 8888 or support@oricom.com.au.
- A Customer Support Team member will verify after troubleshooting with you if your product qualifies under warranty. If so, they will give you a Product Return Authorisation number.
- We will then email or fax a Return Authorisation form and a Repair Notice (if necessary), together with instructions on how to return the goods for warranty service.

Please note that if a Customer Support Team member advises that your product does not qualify for return, this warranty does not apply to your product. Products that are authorised to be returned to Oricom in Australia must include all of the following:

- A completed Return Authorisation form
- A copy of your Proof of Purchase (please keep your original copy)
- The faulty product, including all accessories.

Send the approved returns to:

Oricom International Pty Ltd
Locked Bag 658
South Windsor NSW 2756 Australia

Please note that this Express Warranty excludes expenses incurred by you in returning any faulty product to us. You must arrange and pay any expenses incurred (including postage, delivery, freight, transportation or insurance of the product) to return the faulty product to us, however, we will arrange delivery of the repaired or replaced faulty product to you.

Important Information

Repair Notice

Please be aware that the repair of your goods may result in the loss of any user-generated data (such as stored telephone numbers, text messages and contact information). Please ensure that you have made a copy of any data saved on your goods before sending for repair. Please also be aware that goods presented for repair may be replaced by refurbished goods or parts of the same type rather than being repaired.

ORICOM CUSTOMER SUPPORT

Oricom have a trained and dedicated team of Customer Support Representatives, each with the knowledge and resources to assist in answering your questions quickly and efficiently.

Oricom Support - Australia

For all product enquiries, troubleshooting or to discuss the range of Oricom products, feel free to contact Oricom or visit our website for answers to frequently asked questions.

(02) 4574 8888

Monday - Friday 8am – 6pm AEST

Email: support@oricom.com.au

www.oricom.com.au

Oricom Support - New Zealand

0800 674 266

Monday - Friday 11am - 7pm NZST

Email: support@oricom.co.nz

